

## Stationary placing boom HGR 36

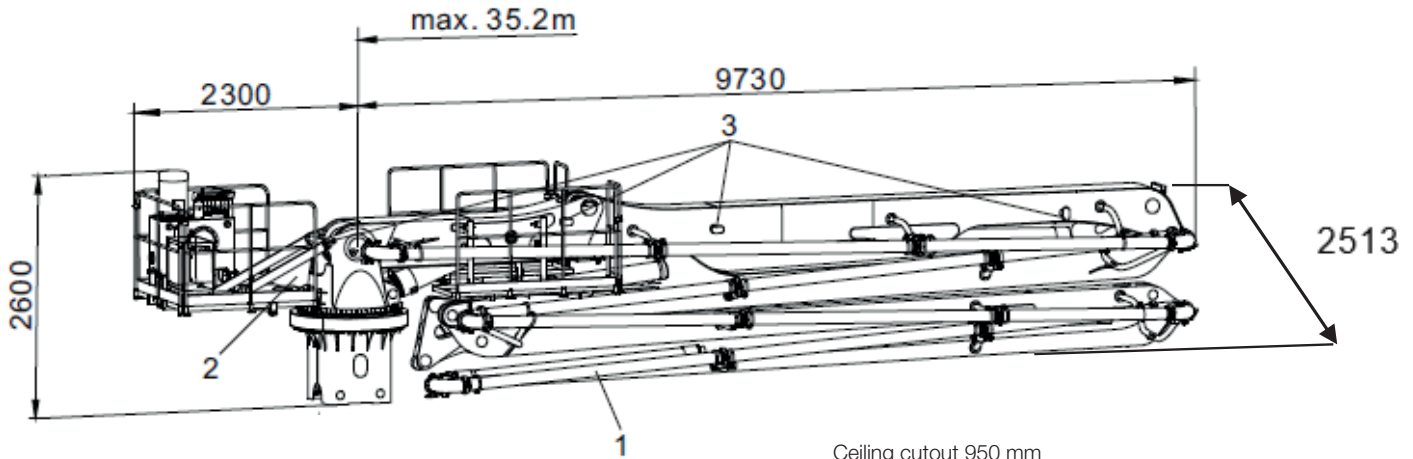

Note: Standard version. Dimensions and weights depend on model and equipment. For illustration only.

- 1 4-section arm assembly with concrete line 125 mm diameter, arm 1 split and 3 m end hose
- 2 Revolving table with mounted hydraulic unit 15 kW 380V 50Hz (on request special voltage and frequency), hydraulic oil tank and electric control cabinet
- 3 Crane hooks

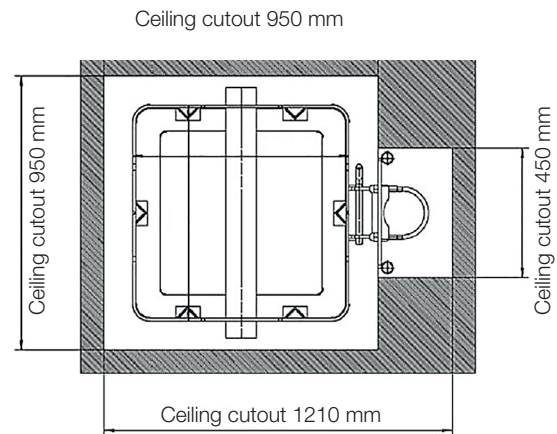

Technical data		
Boom	Folding system	4-arm Z
	Vertical reach	35.2 m
	Horizontal reach	35.2 m
	Reach depth	28.6 m
	Delivery line	DN 125
	End hose length	3 m
	Max. column height	18 m
	Slewing range	365 °
Dimensions	Overall length	12030 mm
	Width	2513 mm
	Height	2600 mm
Weight	Placing boom	4.5 t
	Pedestal without powerpack	3.7 t

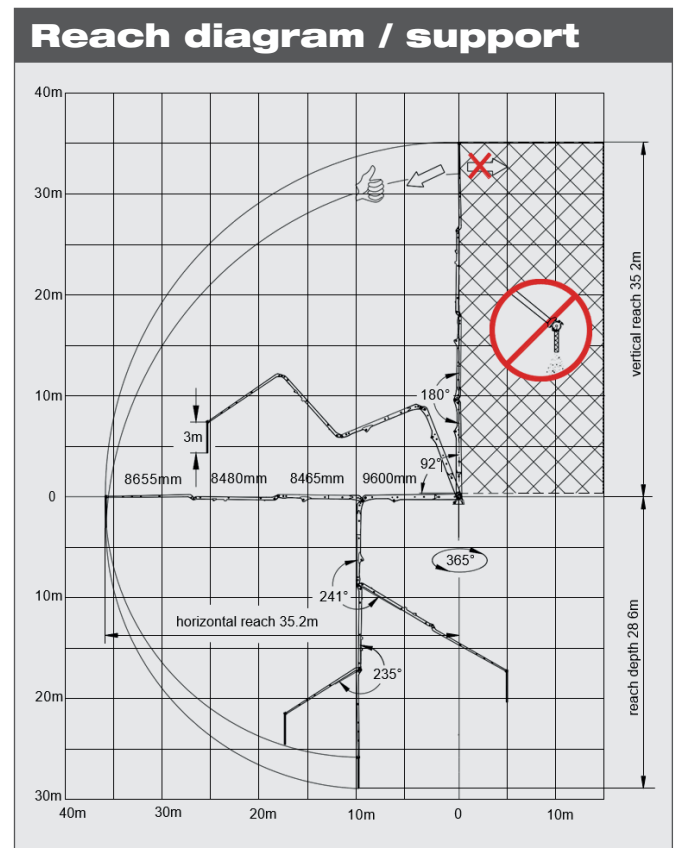

## Standard Equipment HGR 36

Boom	Arm assembly HGR incl. transportation frame
	Boom control, proportional
	Boom pedestal
	Delivery line (2-layer), DN 125, 5.5"
	E-motor, 15 kW, star-delta start
	El.-hydraulic power pack 15 kW 380 V/50 Hz
	End hose 3 m, DN 125
	Operating instruction and spare parts manual English (1 set paper)
	Paintwork arm assembly / base structure: SANY red
	Radio remote control, proportional
	Tool kit incl. standard equipment

Column	Climbing device (3 pcs floor frame, climbing cylinders and bolts)
	Cruciform base „X version“
	Ladder sections with rear protection
	Set of cross bars for cruciform base „X version“ <b>w/o foundation anchoring</b>
	Tubular column 2 x 9 m, with pipework
	Working platform

## Available Options

Cruciform base, ballasted
Special voltage 480 V/60 Hz
Tubular columns 3 x 6 m, instead of standard 2 x 9 m

For sale outside EU countries.

See quotation for exact serial delivery scope.

Materials and specifications are subject to change without further notice in accordance with our continuous technical innovations. Photos and illustrations may include additional equipment.

All rights reserved. 2111

## Putzmeister Concrete Pumps GmbH

Max-Eyth-Straße 10 · 72631 Aichtal, Germany

P.O.Box 2152 · 72629 Aichtal

Tel. +49 (7127) 599-0 · Fax +49 (7127) 599-520

pmw@putzmeister.com · www.putzmeister.com