

# Stationary concrete pump

# BSA 1005 H D4F

Output up to 50 m<sup>3</sup>/h  
Delivery pressure up to 101 bar

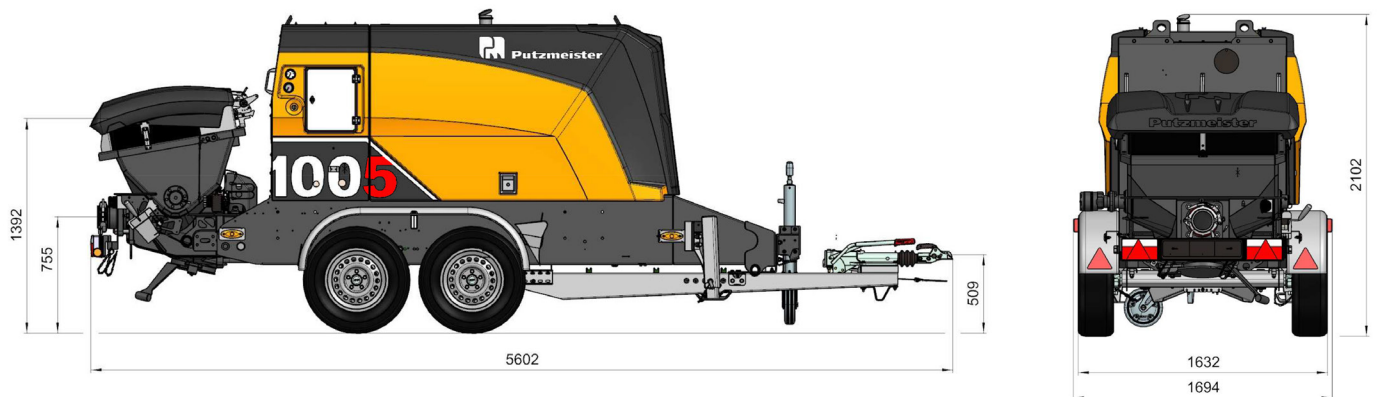

Dimensions and weights depend on equipment. Subject to technical modifications and errors.

## Technical data

Model		BSA 1005 H D4F "NZ"
Material number		103006.000
Output	m <sup>3</sup> /h	50
Delivery pressure	bar	101
Delivery cylinder	Ø mm	150
Delivery cyl. stroke	mm	1000
Strokes / minute		46
Engine / motor power	kW	90
Hopper		RS 458
Capacity	l	approx. 300
Filling height	m	1.46
Transfer tube		S 1512
Line connection	mm	SK 125
Pressure connection	"	5.5
Control system		Ergonic 3 PS
Diesel tank	l	120
Weight	kg	3350

## Serial equipment

Agitator safety switch off	Ergonic Graphic Display
Cable remote control 10 m	Flushing water pump 50 l/min 20 bar
Central lubrication, grease gun	Grill 60 mm
Chassis tandem axle for highway, overrun brake	Horn
Cleaning accessories	Lifting points, 4 ×
Coloring: Pump, frame, roof anthracite-grey Doors chrome yellow	Operating manuals, spare part list
Concrete hopper with agitator	Output adjustment, electrical
Delivery pistons LongLife®	Outriggers 3 × mech.
Delivery pressure reduction to 40 bar	Radio Remote Control
Drive diesel, CAT 90 kW, Tier 4f	Speed drawdown automatically on pump stop
Electronic error management	Splash guard foldable, incl. hopper lights
2nd Emergency stop	Standard equipment
	Support wheel
	Tow coupler, 2" ball

All data maximum theoretical

See quotation for exact serial delivery scope.  
Comprehensive range of options available on request.